

 warning	<p>This unit uses a flammable refrigerant.</p> <p>If the refrigerant leaks and comes into contact with the fire or heating part, harmful gases will be created and there is a risk of fire.</p>
	<p>Read the INSTRUCTION MANUAL before using the appliance.</p>
	<p>Information available in the INSTRUCTION MANUAL.</p>
	<p>Service personnel must read the INSTRUCTION MANUAL carefully before proceeding.</p>

IMPORTANT SAFETY MEASURES

When using electrical appliances, basic rules should always be followed to reduce the risk of fire, electric shock, and personal injury, including the following:

1. This appliance can be used by children aged 8 years and above and persons with reduced physical, sensory or mental capabilities or lack of experience and knowledge if they have been given appropriate supervision or training regarding use of the appliance in a safe manner. and they understand the dangers involved. Children should not play with the device. Cleaning and maintenance to be carried out by the user should not be carried out by children without supervision.
2. Children should be supervised to ensure that they do not play with this appliance.

3. Keep the appliance and its cord out of the reach of children under 8 years of age.
4. CAUTION: For the safety of your children, do not leave packaging material (plastic bags, cardboard, polyethylene, etc.) within their reach.
5. If the power cord is damaged, it must be replaced by the manufacturer, service center or any other qualified professional in order to avoid a hazard.
6. Never disconnect by pulling on the cable.
7. Do not operate the appliance if the cord or plug is damaged or if you notice that the appliance is not working properly.
8. Do not handle the appliance with wet hands.
9. Do not submerge the device in water or any other liquid.
10. Before cleaning, make sure that the device is unplugged.
11. The appliance must be installed in accordance with national regulations for electrical installations.
12. This appliance is for domestic use only.
13. If you need a copy of the instruction manual, you can find it at www.orbegozo.com.
14. WARNING: In case of misuse, there is a risk of possible injuries.

REFRIGERANT R290

Additional warnings for appliances using R290 gas (refer to the rating plate for the type of refrigerant gas used)

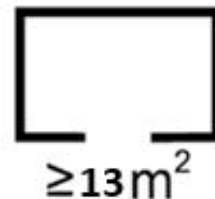

READ THE MANUAL CAREFULLY BEFORE USING THE APPLIANCE.

- R290 refrigerant gas complies with European environmental directives.
- This device contains approximately 260g of R290 refrigerant gas.
- The maximum nominal air flow rate is 420m³/h.
- Do not pierce or burn.
- Use only utensils recommended by the manufacturer for defrosting or cleaning.
- Do not use the appliance in a room where there are continuously operating ignition sources (e.g., open flames, an operating gas appliance, or an operating electric heater).
- Do not puncture any of the components in the cooling circuit.
- Refrigerant gas can be odorless.
- A surface area greater than 13m² is required for the installation, use and storage of the device.
- Stagnation of potential refrigerant gas leaks in unventilated rooms could cause a fire or explosion hazard if the refrigerant comes into contact with electric heaters, stoves, or other ignition sources.
- Take care when storing the device to avoid mechanical failures.
- Only authorized persons whose competence has been accredited by an agency that certifies them to handle refrigerants, in accordance with industry legislation, should work on refrigerant circuits.

- Maintenance and repairs that require the assistance of other qualified personnel must be carried out under the supervision of specialists in the use of flammable refrigerants.

WARNING

Do not use any means to accelerate the defrosting or cleaning process other than those recommended by the manufacturer.

The appliance should be stored in a room where no ignition sources are continuously operating (e.g., open flames, a running gas appliance, or a running electric heater).

Do not pierce or burn.

It should be noted that refrigerants may not have an odor.

The device must be installed, operated and stored in a room with a floor area greater than 13m²

NOTE: The manufacturer may provide other suitable examples or may provide additional information about the refrigerant smell.

INSTRUCTIONS FOR REPAIRING APPLIANCES CONTAINING R 290

1 GENERAL INSTRUCTIONS

1.1 Checks in the area

Before beginning work on systems containing flammable refrigerants, safety checks must be performed to ensure the risk of ignition is minimized. The following precautions must be observed before repairing the refrigeration system.

1.2 Work procedure

The work will be carried out under a controlled procedure, so as to minimize the risk of the presence of any flammable gas or substance while the work is being carried out.

1.3 General work area

All maintenance personnel and all individuals working in the local area must be instructed on the nature of the work to be carried out. Work in confined spaces must be avoided. The area around the work zone must be cordoned off. Flammable material checks must be performed to ensure that conditions within the area are safe.

1.4 Check for presence of refrigerant

The area must be checked with an appropriate refrigerant leak detector before and during work to ensure the technician is aware of potentially flammable atmospheres. It must be verified that the leak detection equipment used is suitable for use with flammable refrigerants; that is, it is non-sparking and properly sealed or intrinsically safe.

1.5 Presence of fire extinguisher

If hot work is to be performed on the refrigeration equipment or any associated parts, appropriate fire extinguishing equipment must be available. A dry powder or CO2 fire extinguisher must be located near the loading area.

1.6 No ignition sources

No person performing work on a refrigeration system involving exposed piping containing or having contained flammable refrigerant shall use any ignition source that could create a risk of fire or explosion. All potential ignition sources, including cigarette smoke, must be kept well away from the installation, repair, removal, and disposal area for as long as flammable refrigerant could be released into the surrounding space. Before work begins, the area around the equipment must be inspected to ensure there are no flammable or ignition hazards. "No Smoking" signs must be posted.

1.7 Ventilated area

Ensure the area is outdoors or adequately ventilated before entering the system or performing any hot work. A degree of ventilation must be maintained throughout the work. Ventilation should safely disperse any released refrigerant and preferably expel it externally into the atmosphere.

1.8 Refrigeration equipment checks

When electrical components are replaced, they must be adapted to their intended purpose and the correct specifications. The manufacturer's maintenance and service guidelines must be followed at all times. If in doubt, consult the manufacturer's technical department for assistance. The following checks must be performed on installations using flammable refrigerants:

- The load size is in accordance with the size of the room within which the parts containing refrigerant are installed.
- The ventilation outlets and machinery are properly operated and not obstructed.
- If an indirect cooling circuit is used, the secondary circuit must be checked for the presence of refrigerant.
- The equipment markings remain visible and legible. Any illegible markings and symbols must be corrected.
- Cooling components or piping are installed in a position where they are not likely to be exposed to any substance that may corrode the components containing refrigerant, unless the components are constructed of materials that are inherently corrosion-resistant or are adequately protected against corrosion.

1.9 Checks on electrical devices

The repair and maintenance of electrical components must include initial safety checks and inspection procedures. If a fault exists that could compromise safety, the electrical supply to the circuit must not be connected until it has been satisfactorily resolved. If the fault cannot be corrected immediately, but continued operation is necessary, a suitable temporary solution must be implemented. The equipment owner must be informed of this so that all parties involved can be advised.

Initial security checks should ensure the following:

- The capacitors will be discharged: this must be done safely to avoid sparks;
- There will be no electrical components under electrical voltage or exposed cables when charging, recovering or purging the system;
- There will be continuity of grounding.

2. REPAIR OF SEALED COMPONENTS

2.1 During repairs of sealed components, before removing sealed covers and other parts, all electrical supplies must be disconnected from the equipment being worked on. If it is absolutely necessary to

keep an electrical supply connected to the equipment during maintenance, then a continuously operating leak detection system must be installed at the most critical point to warn of any potentially hazardous situation.

2.2 Special attention will be paid to the following to ensure that, when working with electrical components, the enclosure is not altered in such a way that the level of protection is affected. This includes damage to cables, an excessive number of connections, terminals not made according to the original specifications, damage to seals, incorrect installation of cable glands, etc.

You must ensure that the device is mounted securely.

Check that the seals or sealing materials have not degraded to the point where they are no longer effective in preventing the entry of flammable atmospheres. Replacement parts must comply with the manufacturer's instructions.

NOTE: The use of silicone sealant may inhibit the effectiveness of some types of leak detection equipment. It will not be necessary to isolate intrinsically safe components before working on them.

3. REPAIR OF INTRINSICALLY SAFE COMPONENTS

Do not apply permanent inductive or capacitive loads to the circuit without first ensuring that this does not exceed the voltage and current allowed for the equipment in use.

Intrinsically safe components are the only types that can be worked on in a flammable atmosphere. The test equipment must be correctly rated. Replace components only with parts specified by the manufacturer. Other parts may cause the refrigerant to ignite in the atmosphere due to a leak.

4 WIRING

Verify that the wiring is not subjected to wear, corrosion, excessive pressure, vibration, sharp edges, or other adverse environmental effects. The verification will also consider the effects of aging or continuous vibration from sources such as compressors or fans.

5. DETECTION OF FLAMMABLE REFRIGERANTS

Under no circumstances should potential ignition sources be used when searching for or detecting refrigerant leaks. A halide torch (or any other open flame detector) should not be used.

6 LEAK DETECTION METHODS

The following leak detection methods are considered acceptable for systems containing flammable refrigerants.

Electronic leak detectors must be used to detect flammable refrigerants. However, their sensitivity may be inadequate or they may require recalibration. (The detection equipment must be calibrated in an area free of refrigerant.) Ensure that the detector is not a potential ignition source and that it is suitable for the refrigerant being used. The leak detection equipment will be set to a percentage of the refrigerant's LFL and calibrated against the refrigerant in use. Additionally, the appropriate percentage of gas (25% maximum) will be confirmed.

Leak detection fluids are suitable for use with most refrigerants, but detergents containing chlorine should be avoided, as chlorine can react with the refrigerant and corrode copper pipes.

If a leak is suspected, all live flames will be eliminated/extinguished.

If a refrigerant leak requiring brazing is found, all the refrigerant must be recovered from the system or isolated (using shut-off valves) at the system termination point where the leak is located. Oxygen-free nitrogen (OFN) must be purged through the system before and during the brazing process.

7 EXTRACTION AND EVACUATION

When entering the refrigerant circuit for repairs—or any other purpose—standard procedures will be used. However, it is important to follow best practices, as flammability is a consideration. The following procedure should be followed:

- Remove the refrigerant.
- Purge the circuit with inert gas.
- Evacuate.
- Purge again with inert gas.
- Open the circuit by cutting or soldering.

The refrigerant charge will be recovered in the appropriate recovery cylinders. The system must be purged or flushed with OFN to ensure the unit is safe. This process may need to be repeated several times. Compressed air or oxygen will not be used for this task.

The system will be flushed out of the vacuum using oxygen-free nitrogen while continuing to fill it until the maximum working pressure is reached. It will then be vented to the atmosphere and finally released back into the vacuum. This process will be repeated until no refrigerant remains in the system. When the final charge of oxygen-free nitrogen is used, the system will be vented to atmospheric pressure to allow work to proceed. This operation is absolutely vital if welding operations are to be performed on the piping. Ensure that the vacuum pump outlet is not near any ignition source and that adequate ventilation is available.

8 LOADING PROCEDURES

In addition to conventional loading procedures, the following requirements will be followed:

- Ensure that no contamination occurs from different refrigerants when using charging equipment. Hoses or lines should be as short as possible to minimize the amount of refrigerant they contain.
- The cylinders must be kept in a vertical position.
- Check that the cooling system is grounded before charging it with refrigerant.
- Label the system when the load is complete (if it is not already).
- Extreme care must be taken to avoid overfilling the cooling system.

Before recharging the system, it will undergo a pressure test with oxygen-free nitrogen. The system will be leak-tested after charging, but always before startup. A follow-up leak test must be performed before leaving the site.

9 DEACTIVATION

Before performing this procedure, it is essential that the technician be fully familiar with the equipment and all its features. Good practices are recommended to ensure the safe recovery of all refrigerants. Before starting the work, an oil and refrigerant sample will be taken in case analysis is required before reusing the recovered refrigerant. It is essential that electrical power is available before beginning the task.

- a) You need to become familiar with the equipment and how it works.
- b) Electrically isolate the system.
- c) Before attempting the procedure, you must ensure the following:

Mechanical handling equipment will be available, if necessary, to handle refrigerant cylinders;

All personal protective equipment will be available and being used correctly; the recovery process will be supervised at all times by a competent person; the recovery equipment and cylinders conform to the appropriate standards.

- d) Pump the refrigerant system, if possible.

e) If a vacuum is not possible, make a manifold so that the refrigerant can be removed from various parts of the system.

f) It is necessary to ensure that the cylinder is positioned on the scale before the process takes place recovery .

- g) Start the recovery machine and operate it according to the manufacturer's instructions.

- h) Do not overload the cylinders. (No more than 80% of the liquid charge volume).
- i) Do not exceed the maximum working pressure of the cylinder, even temporarily.
- j) When the cylinders have been filled correctly and the process is complete, it must be verified that the cylinders and equipment are removed from the site quickly and that all equipment isolation valves are closed.
- k) The recovered refrigerant must not be charged into another refrigeration system unless it has been cleaned and checked.

10 LABELING

The equipment must be labeled indicating that it has been deactivated and drained of refrigerant. The label must be dated and signed. Verify that there are labels on the equipment indicating that it contains flammable refrigerant.

11 RECOVERY

When removing refrigerant from a system, whether for servicing or decommissioning, it is recommended as a good practice that all refrigerants are disposed of safely.

When transferring refrigerant to cylinders, ensure that only appropriate refrigerant recovery cylinders are used. Ensure that the correct number of cylinders is available to maintain the system's full charge. All cylinders used must be designated for recovered refrigerant and labeled accordingly (i.e., dedicated refrigerant recovery cylinders). The cylinders must be complete with a pressure relief valve and associated shut-off valves in good working order. Empty recovery cylinders must be evacuated and, if possible, cooled before recovery takes place.

The recovery equipment must be in good working order (with a set of instructions on said equipment available) and must be suitable for recovering flammable refrigerants.

In addition, a set of calibrated scales must be available and in good working order. Hoses must be complete with leak-free disconnect couplings in good condition. Before using the recovery equipment, verify that it is functioning correctly, has been properly maintained, and that its associated electrical components are sealed to prevent ignition in the event of a refrigerant release. If in doubt, consult the manufacturer.

The recovered refrigerant will be returned to the refrigerant supplier, stored in the correct recovery cylinder, and the corresponding Waste Transfer Note will be prepared. Do not mix refrigerants in recovery units, and especially not in cylinders.

If compressors or compressor oils must be removed, ensure that the system has been evacuated to an acceptable level to verify that no flammable refrigerant remains in the lubricant. The evacuation process must be carried out before returning the compressor to the suppliers. Only electrical heating should be applied to the compressor body to accelerate this process. When draining oil from a system, this must be done safely.

Competence of service personnel

General

Special training in addition to the usual refrigeration equipment repair procedures is required when the equipment is affected by flammable refrigerants.

In many countries, this training is carried out by national training organizations that are accredited to teach the relevant national competency standards that may be established in legislation.

The competence obtained must be documented by means of a certificate.

Training

The training should include the following:

Information on the explosion potential of flammable refrigerants to demonstrate that flammable materials can be dangerous if handled carelessly.

Information on possible ignition sources, especially those that are not obvious, such as lighters, light switches, vacuum cleaners, electric heaters.

Information on the different security concepts:

Without ventilation - (see Clause GG.2) The safety of the appliance does not depend on the ventilation of the dwelling. Switching off the appliance or opening the casing has no significant effect on safety. However, refrigerant leaks may accumulate inside the enclosure, and a flammable atmosphere will be released when the enclosure is opened.

Ventilated room - (see Clause GG.4) The safety of the appliance depends on the ventilation of the dwelling. Switching off the appliance or opening the cabinet has a significant effect on safety. Care must be taken to ensure sufficient ventilation beforehand.

Ventilated room - (see Clause GG.5) The safety of the appliance depends on the ventilation of the room. Switching off the appliance or opening the casing has no significant effect on safety. The room ventilation must not be switched off during repair procedures.

Information on the concept of sealed components and sealed enclosures according to IEC 60079-15: 2010.

Information on correct work procedures:

a) Commissioning

- Ensure that the floor area is sufficient for the refrigerant charge or that the ventilation duct is properly assembled.
- Connect the pipes and perform a leak test before charging with refrigerant.
- Check the safety equipment before putting it into service.

b) Maintenance

- Portable equipment must be repaired outdoors or in a workshop specially equipped for servicing units with flammable refrigerants.
- Ensure there is sufficient ventilation at the repair site.
- Please note that equipment malfunction may be due to refrigerant loss and a refrigerant leak is possible.
- Discharge the capacitors in a way that does not cause sparks. The standard procedure for short-circuiting the capacitor terminals usually creates sparks.
- Reassemble the sealed cabinets precisely. If the seals are worn, replace them.
- Check the safety equipment before putting it into service.

c) Fix

- Portable equipment must be repaired outdoors or in a workshop specially equipped for the maintenance of units with flammable refrigerants.
- Ensure there is sufficient ventilation at the repair site.
- Please note that equipment malfunction may be due to refrigerant loss and a refrigerant leak is possible.
- Discharge the capacitors in a way that does not cause sparks.

• When brazing is required, the following procedures shall be carried out in the correct order:

Remove the refrigerant. If recovery is not required by national regulations, drain the refrigerant to the outside. Take care that the drained refrigerant does not pose any hazards. If in doubt, one person should supervise the draining process. Take special care to ensure that the drained refrigerant does not re-enter the building.

- Evacuate the refrigeration circuit.
- Purge the refrigeration circuit with nitrogen for 5 min.
- Evacuate again.
- Remove the parts to be replaced by cutting, not with a flame.
- Purge the brazing point with nitrogen during the brazing procedure.
- Perform a leak test before charging with refrigerant.
 - Reassemble the sealed cabinets precisely. If the seals are worn, replace them.
 - Check the safety equipment before putting it into service.
- d) Dismantling
 - If safety is compromised when the equipment is taken out of service, the refrigerant charge will be removed before taking the equipment out of service.
 - Ensure there is sufficient ventilation at the equipment location.
 - Please note that equipment malfunction may be due to refrigerant loss and a refrigerant leak is possible.
 - Discharge the capacitors in a way that does not cause sparks.
 - Remove the refrigerant. If recovery is not required by national regulations, drain the refrigerant to the outside. Take care that the drained refrigerant does not pose any hazards. If in doubt, one person should supervise the drain. Take special care to ensure that the drained refrigerant does not re-enter the building.
 - Drain the coolant circuit.
 - Purge the refrigeration circuit with nitrogen for 5 min.
 - Evacuate again.
 - Fill with nitrogen to atmospheric pressure.
 - Place a label on the equipment indicating that the refrigerant has been removed.
- e) Provision
 - Ensure there is sufficient ventilation in the workplace.
 - Remove the refrigerant. If recovery is not required by national regulations, drain the refrigerant to the outside. Take care that the drained refrigerant does not pose any hazards. If in doubt, one person should supervise the drain. Take special care to ensure that the drained refrigerant does not re-enter the building.
 - Drain the coolant circuit.
 - Purge the refrigeration circuit with nitrogen for 5 min.
 - Evacuate again.
 - Turn off the compressor and drain the oil.

Transport, marking and storage of units using flammable refrigerants. Transport of equipment containing flammable refrigerants.

Attention is drawn to the fact that additional transport regulations may apply to equipment containing flammable gas. The maximum number of pieces of equipment or the configuration of equipment permitted to be transported together will be determined by the applicable transport regulations.

Equipment marking using signs

Signage for similar appliances used in a work area is generally governed by local regulations and provides the minimum requirements for the provision of safety and/or health signage for a workplace. All required signs must be maintained and employers must ensure that employees receive adequate and sufficient instruction and training on the meaning of appropriate safety signs and the actions to be taken in relation to these signs.

The effectiveness of signs should not be diminished by placing too many signs together. The pictograms used should be as simple as possible and contain only essential details.

Disposal of equipment that uses flammable refrigerants

Consult national regulations.

Equipment/appliance storage

The equipment must be stored in accordance with the manufacturer's instructions.

Storage of packaged (unsold) equipment: The storage package protection must be constructed so that mechanical damage to the equipment inside the package does not cause a leak of the refrigerant charge.

The maximum number of pieces of equipment that can be stored together will be determined by local regulations.

WARNINGS

Do not get the casing or control panel wet.



Do not place objects on top of the unit or allow anyone to sit on it.



Unplug the unit when you are not going to use it for an extended period of time

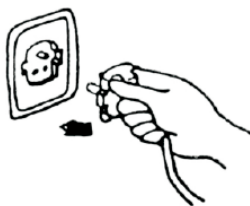

Do not cover the air outlet while using the appliance



Turn off the unit and unplug it when you are going to perform cleaning tasks

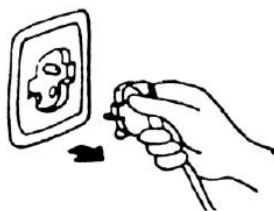

Use only the correct electronic supply. 220-240v ~50HZ



Do not let children play with the buttons or insert any objects into the air outlet.



Do not attempt to remove any parts from the casing. This should only be done by an authorized technician.



Do not operate the unit if the plug is damaged or the socket is loose.



PARTS DESCRIPTION

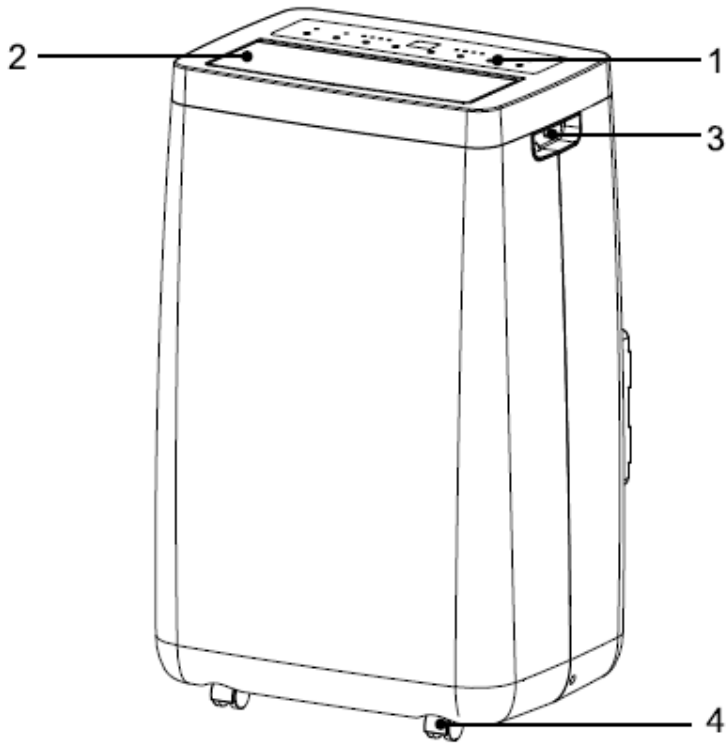

1. Control Panel

2. Air outlet

3. Hole for the handle

4. Wheel

5. Air filter

6. Air Inlet (Evaporator)

7. Air outlet (Heat exchanger)

8. Air Inlet (Condenser)

9. Water outlet drain

10. Water outlet drain (Dehumidification

mode only)

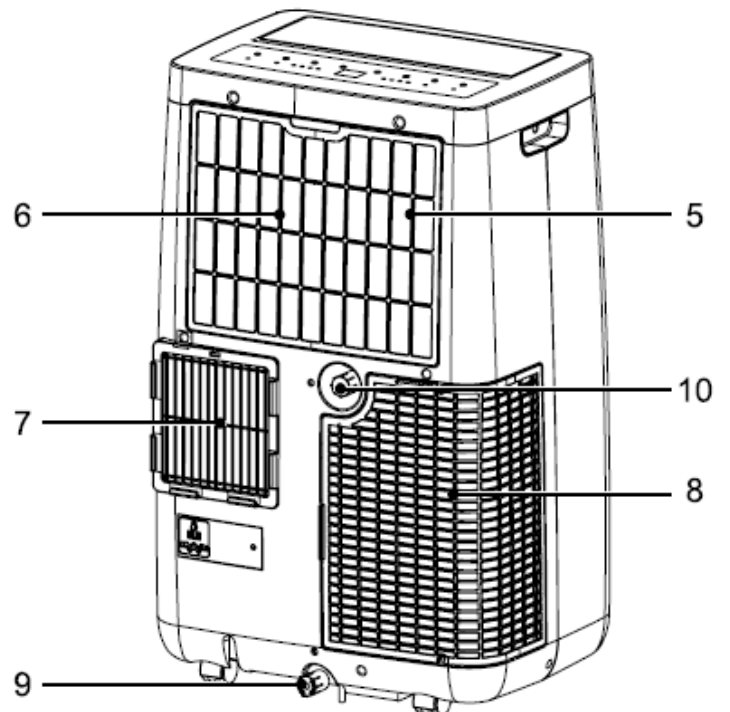

Note: Ensure the water outlet drain is properly installed before use.

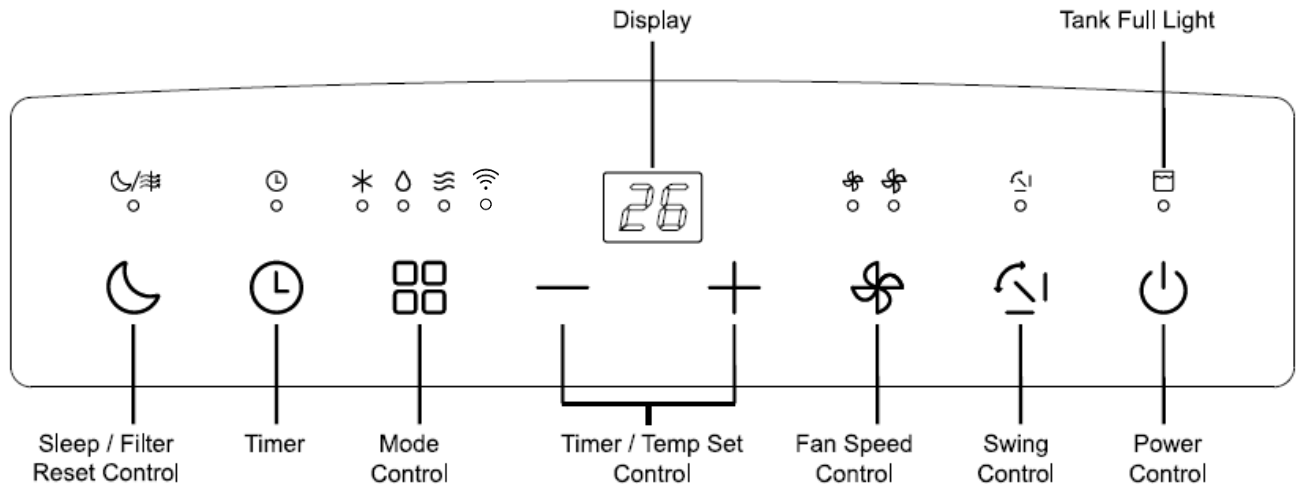

OPERATING INSTRUCTIONS

ON / OFF
 Press the button to turn on the air conditioner.

FULL TANK
 This light will come on when the tank is full to remind you to empty it in order to continue using the appliance.

TIMER
Automatic shutdown:

With the machine in operating mode, press the timer button to set the timer control. Press "+" or "-" to select the number of hours you want the unit to run before it automatically shuts off.

Automatic ignition:

With the machine in standby mode, press the timer button to set the timer control. Press "+" or "-" to select the number of hours before the unit will automatically start operating in air conditioning mode.

Note: The time can be adjusted between 1 and 24 hours.

MODE
 Cooling, dehumidification, and ventilation modes.

The settings are changed using the Mode Control button. A light will indicate which setting is currently in use.

- **Cooling mode**



During cooling mode, the air is cooled and the hot air is expelled to the outside through the outlet tube.

Adjust the fan speed according to the temperature to suit your desired comfort level. The temperature adjustment range is 16°C to 32°C.

Note: The air exchange hoses must have an outlet to the outside when using cooling mode.

- **Dehumidification mode**



The air is dehumidified as it passes through the unit, without entering full cooling mode.

- If the ambient temperature is above 25°C, the fan speed can be adjusted.
- Otherwise, the fan speed is set to "low".

Note: If the unit is to be used as a dehumidifier, **do not connect the exhaust hose to the outside** ; allow the warm air to return to the room. In this case, continuous drainage will be required.

- **Fan Mode** 

The air circulates throughout the room without cooling.

Note: It is not necessary to ventilate the unit in fan mode.



FAN SPEED

The fan has two speeds, high and low. Press the button to change the speed. The corresponding indicator will light up.



TEMPERATURE/TIME SETTING

TEMPERATURE CONTROLS

They are used to adjust the thermostat.

The default display shows the ambient temperature.

In cooling mode, pressing the "+" or "-" buttons displays the set temperature and allows you to adjust it.

After a few seconds, the display will return to the ambient temperature. The temperature can only be adjusted in cooling mode.

NOTE: Pressing the "+" and "-" buttons simultaneously will switch the display between Celsius and Fahrenheit.



FILTER RESET

After 500 hours of operation, the filter indicator light will illuminate to remind you to clean the air filter.

1. Clean the air filter.
2. Press this button to reset the air filter timer and turn off the filter check indicator.



SLEEP MODE BUTTON

Press the Night Mode button in any operating mode to activate Sleep Mode. In this setting:

- The internal fan will operate at low speed.
- The fan speed indicator will turn off and manual speed adjustment will be disabled.

Cooling Mode

When Sleep Mode is active in Cooling mode:

1. The set temperature will automatically increase by 1°C (2°F) per hour.
2. After a total increase of 2°C (4°F), the temperature will remain stable.

To exit Sleep Mode: Press the Night Mode button again or change the operating mode to deactivate this function.



OSCILLATION CONTROL

The OSCILLATION button moves the grille flap, distributing air evenly throughout the room.

When you press the OSCILLATION button, the fin will begin to alternately move up and down.

If pressed again, the flap will lock in its current position.

Pressing the button again will cause the fin to start moving up and down again.

NOTE: To avoid damaging the internal mechanisms, the flap should not be moved manually.

NOTE: After turning off the air conditioner, you must wait 3 minutes before turning it back on.

WIFI CONNECTION

WIFI function

- The unit can be conveniently controlled remotely via an app. Please scan the QR code below or search for '**Orbegozo APP**' in the App Store/Google Play. To set it up, follow the instructions in the app.



- Wi-Fi indicator light shows the unit's current status. The light cycles through **states 1 through 5** during a new setup. After the unit is successfully connected, it can be controlled via the app. All of the unit's functions are accessible through the app.

- To activate WIFI, press and hold the **power button** for approximately 5 seconds.

LED Indicator States

State	Description	LED
1	Linking-Configuration	Rapid blink
2	Link-AP	Slow blink
3	Successful pairing but no connection to the router	Off
4	Successful pairing and connection to the router	On
5	Successful connection to the application	On
6	WiFi in standby mode	Off

Setting up a timer (Timer)

To schedule automatic operation, follow these steps in the application:

- Cloud Timer** settings button .
- Click on **Add Schedule** .
- Set the desired time(s).
- When the timer is set, press '**Save**' .

Note on the interface: On the programming screen you can select the time, repeat, mode (Cool/Heat) and fan speed before saving.

REMOTE CONTROL

The functions are the same as those on the air conditioner's control panel. All the main functions can be accessed from the remote control.

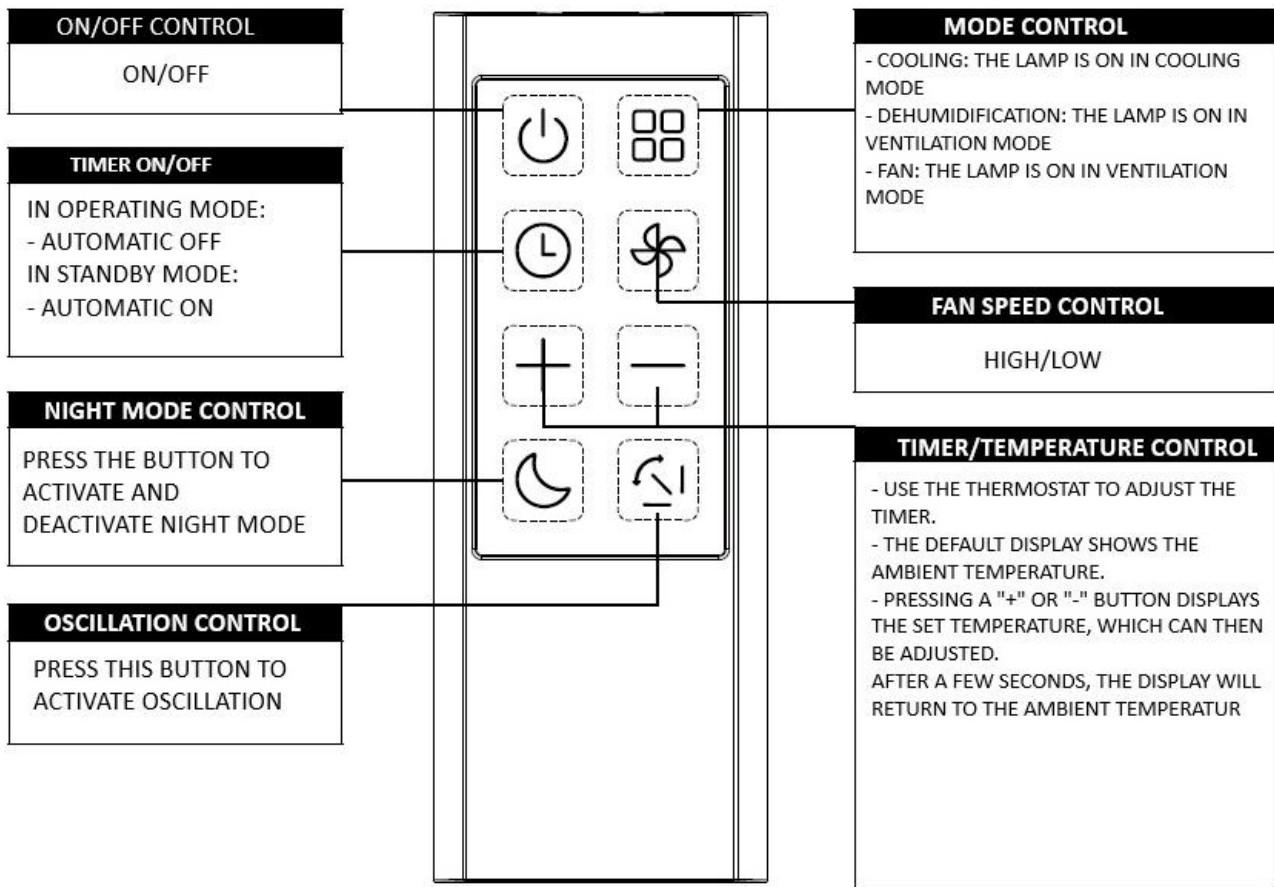

Batteries: Remove the cover from the back of the remote control and insert the batteries with the (+) and (-) poles in the correct position.

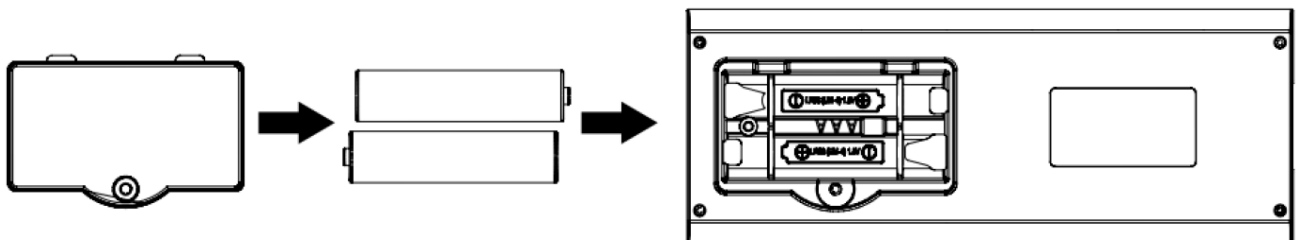

Caution

- Use only AAA or IEC RO3 1.5V batteries.
- Remove the batteries if you will not be using the remote control for a month or more.
- All batteries should be changed at the same time.
- Do not throw batteries into the fire, as they may explode.

ASSEMBLY AND INSTALLATION

INCLUDED ACCESSORIES

- 1. Outlet hose..... 1 unit
- 2. Adapter.....1 unit
- 3. Grid.....1 unit
- 4. Window kit.....3 units
- 5. Lid.....1 unit

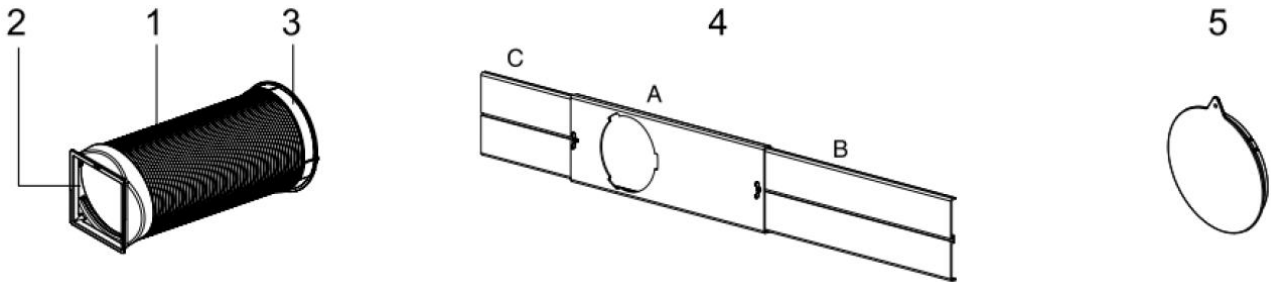

Facility

1. Slide one end of the hose assembly into the back panel.

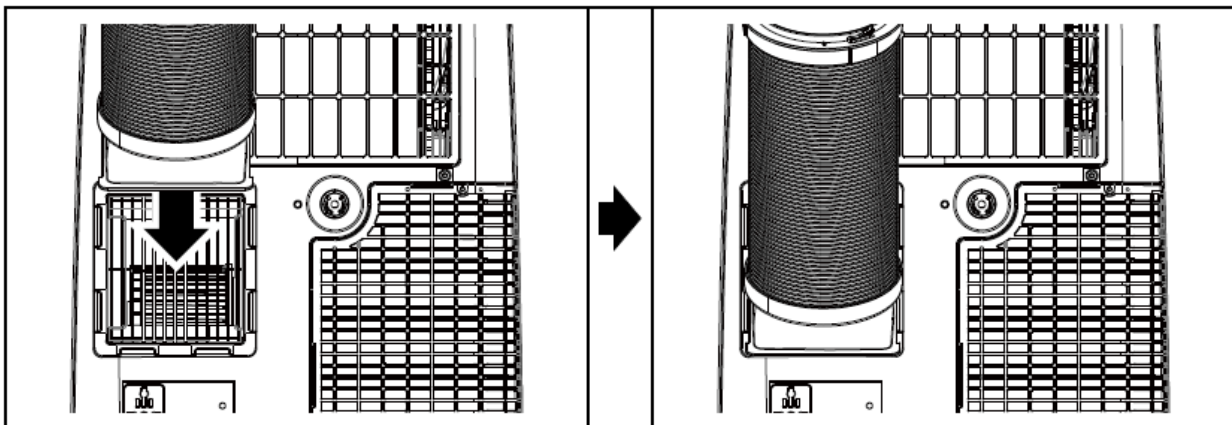

2. Insert window panels B and C into each end of the main panel A. Adjust the length of the window panels using the screws and nuts installed at both ends of the main panel A.

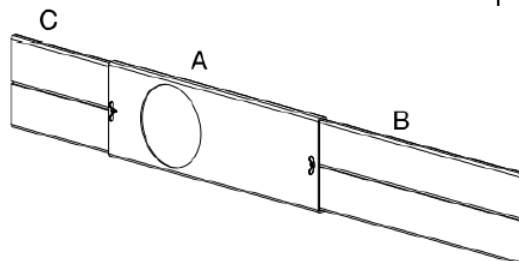

3. Open the window and place the panels inside. Adjust the extension panels to the width or height of the window using the screws and nuts installed on the main panel A.

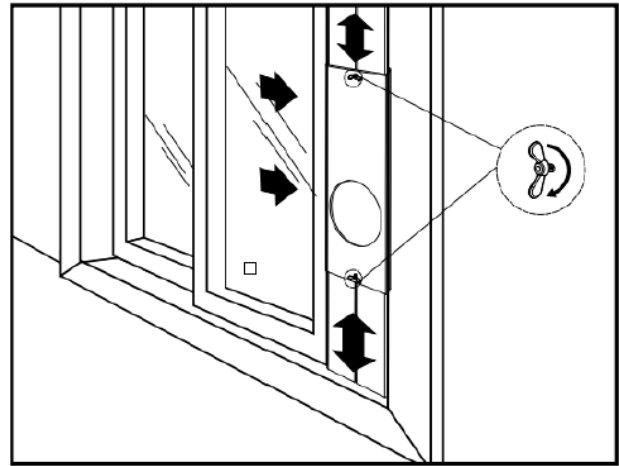
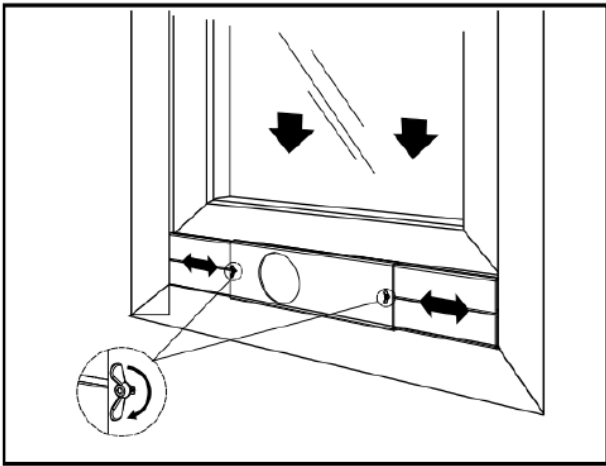

4. Insert the other end of the exhaust hose assembly into the window panel.

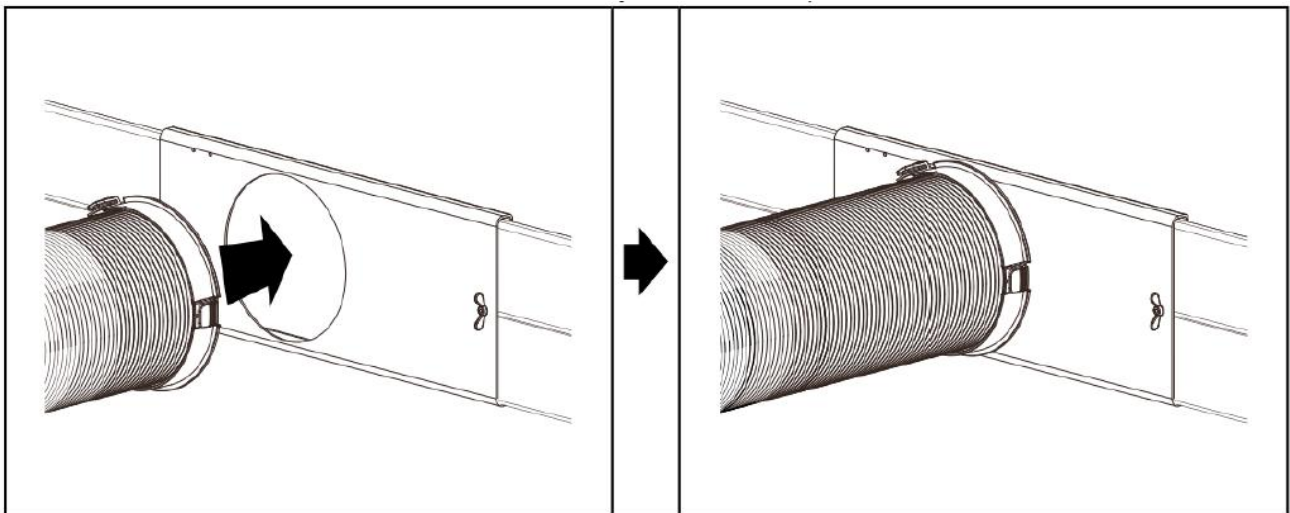

5. Connect the power cord to the power outlet.

6. When removing the portable air conditioner for storage, you can leave the window panel in place. Simply place the cover over the hole in the window panel.

TROUBLESHOOTING

The following cases may not always be due to a malfunction. Please check before contacting technical support:

Problem	Analysis
Not working	<ul style="list-style-type: none"> - The protection mechanism or the fuse is blown. - Wait 3 minutes and turn it on again; the protection device may be preventing the unit from starting. - The batteries in the remote control are dead. - The plug is not properly attached.
It only works for a while. brief period of time	<p>The selected temperature is very close to the room temperature. Lower the set temperature.</p> <ul style="list-style-type: none"> - There may be an obstruction blocking the air outlet. Remove the object.
It works but it doesn't cool	<ul style="list-style-type: none"> - Is there a door or window open? - Is there a heating appliance, such as a stove, a lamp, etc. - The air filter is dirty; clean it. - The air inlet or outlet is blocked. - The selected temperature is too high
It's not working and the indicator the water turns on	<p>Drain the water into a suitable container using the drain tube on the back panel of the unit. If it still does not work, contact a qualified technician.</p>
The screen displays "E1"	<ul style="list-style-type: none"> - Temperature sensor error
The screen displays "E2"	<ul style="list-style-type: none"> - Coil sensor error

CARE AND MAINTENANCE

APPLIANCE MAINTENANCE

1. Disconnect the power supply

Turn off the appliance before disconnecting the supply .



AIR FILTER MAINTENANCE

The air filter needs to be cleaned after about 100 hours of use. To clean it, follow these steps:

2. Clean with a soft, dry cloth.

If it is very dirty, use lukewarm water (below 40°C) to clean the appliance .



1. STOP THE APPLIANCE AND REMOVE THE AIR FILTER

Stop the device first, and then pull the filter towards above .



3. Do not use volatile substances,

Like gasoline or products from powder cleaning, to clean this appliance.



2. Clean the air filter and reinstall it.

If it is very dirty, wash it with warm water and detergent. After cleaning it, dry it in a cool place away from sunlight. Once dry, put it back in its place.

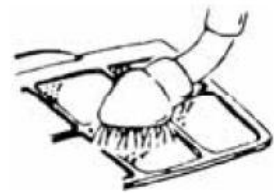

4. Do not spray water on the unit major

Danger! Risk of electric shock.



3. If you use air conditioning in dusty environments, clean the air filter every two weeks.

Maintenance after use

1. If you are not going to use the appliance for an extended period of time, be sure to remove the rubber plug from the drain port at the bottom to drain the water.
2. Leave the appliance running with only the fan on for half a day on a sunny day to dry the inside of the appliance and prevent mold from forming.
3. Stop the device and unplug it. Then, remove the batteries from the remote control and store it.
4. Clean the air filter and replace it.
5. Remove the air tubes and store them. Seal the hole tightly.

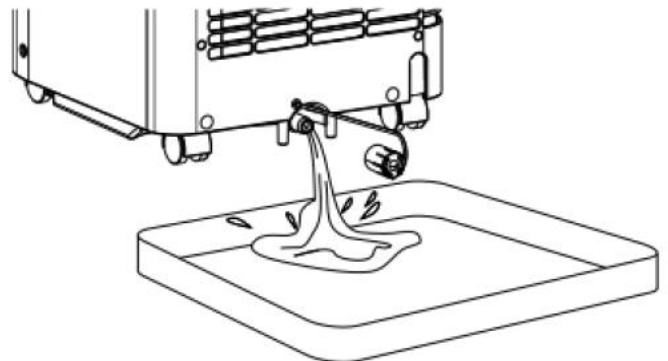

SPECIFICATIONS

Product description	Local air conditioner
Model	ADRW 12000
Voltage/frequency	220-240V ~50Hz.
Input power (cooling)	1350W
Cooling capacity	3000 frigories
Dehumidification capacity	72 L/day
Refrigerant	R290
Timer	24 hours
DIMENSIONS (W x H x D)	42.8 x 67.6 x 32cm
Weight	30kg
Operating temperatures / humidity	16°C~35°C / 30%-80% RH
Fuse type	3.15AH, 250V

DISPOSAL OF OLD ELECTRICAL APPLIANCES



The European directive 2012/19/EU on Waste Electrical and Electronic Equipment (WEEE), requires that old household electrical appliances must not be disposed of in the normal unsorted municipal waste stream. Old appliances must be collected separately in order to optimize the recovery and recycling of the materials they contain, and reduce the impact on human health and the environment. The crossed out "wheeled bin" symbol on the product reminds you of your obligation, that when you dispose of the appliance, it must be separately collected. Consumers should contact their local authority or retailer for information concerning the correct disposal of their old appliance.

DECLARATION OF CONFORMITY:

This device complies with the requirements of the Low Voltage Directive 2014/35/EU and the requirements of the EMC directive 2014/30/EU.

GUARANTEE

This appliance is covered and is entitled to the legal guarantee in accordance with the legislation in force from the date of purchase. Keep the purchase receipt to be able to claim your right to the guarantee. To find the closest service to your location, contact through the following web link: <https://orbegozo.com/asistencia-tecnica/>

For any type of query, doubt or incident, you can contact us through our email shown on the main page of this manual or through our technical assistance service at <https://orbegozo.com/contacto/>

Orbegozo is not responsible for components and accessories that are subject to wear and tear due to use, as well as perishable compounds or those that have deteriorated due to improper use. Nor will it be held responsible if the owner has technically modified the device. Check the legal conditions on our website.